

**GOLDACRES**



**G8 Super Cruiser**

# Built just down the road.



Goldacres is an Australian owned and operated manufacturer of the country's finest spray equipment, produced in Ballarat, Victoria.

From our inception over four decades ago, Goldacres has prospered by constantly reinventing its products and business practices in this fast changing landscape that is modern farming.

Our philosophy is simple;

*“to put farmers in the driver's seat of best fit technology to make them outstanding in their field”*

We are driven by four core values, innovation, uncompromising quality, adaptability and lastly being courageous.

Our sprayers are fully designed, engineered and manufactured in Australia with over 40 years manufacturing experience along with valuable feedback from owners and operators on what is important to you.

The G8 Super Cruiser is Goldacres largest capacity self-propelled model, with numerous features this machine leads the way in efficiency, technology and operator usability.





CRES

GOLDACRES  
EQUIPMENT CENTRE

0213521



***Big on capacity,  
exceptional efficiency.***

GOLDACRES 8042

GOLDACRES  
GOLDACRES

SUPERFLOW



GOLDACRES

 Cabin





# Operator comfort and style.

Centrally located cabin with suspension and an air ride seat to help reduce operator fatigue, mechanical driveline is also quieter by design.

The sprayer is one of the most utilised items of equipment on the farm today. Long hours day after day, places plenty of demand on the operator to get the spraying program completed.

The G8 Super Cruiser cabin makes it all possible, with features like:

- ▶ Seven way adjustable seat.
- ▶ Adjustable side console with G-Motion joystick.
- ▶ Automatic climate control air-conditioning system with carbon filter.
- ▶ Adjustable steering column ensures operators can find the optimal seating position.
- ▶ Padded training seat with seatbelt.
- ▶ Narrow profile four post frame with external truss Roll Over Protective Structure (ROPS).
- ▶ Double skinned rear wall and extensive sound deadening provide a strong, yet peaceful uninterrupted view of the job at hand.



**65.5 db\***

Lowest cabin noise  
in class



# Cabin



320 degree view



# A bird's eye view of all corners of the sprayer.

The high mounted, centrally positioned cabin gives the operator visibility where it counts.

The cabin is mounted high on the chassis, with the bonnet mounted low. This gives an almost completely uninterrupted view from the front window. Visibility through the side and rear windows provides an excellent view of the boom.

The main access platform features longitudinal slots to see through. Curved glass on all four sides with strategically placed narrow profile four post ROPS frame.

The hydraulic reservoir with volume level with temperature gauge and back lit spray pressure gauge are clearly visible.



# Cabin



# Superior ride, Superior comfort.

Multiple suspension systems along with cabin position on the chassis give the operator a smooth comfortable ride.

A cabin positioned behind the front axle gives a naturally superior ride due to the reduced vertical movement. In addition, the suspended cabin, air seat and five link air bag chassis suspension system give the operator a smooth, comfortable ride.

- ▶ Air ride suspension seat
- ▶ Suspended cabin
- ▶ Five link suspension with torque rods, rear anti-sway bar with air bags on all four corners
- ▶ TriTech boom suspension controlling pitch, roll and yaw

## We know that one size does not fit all

Seven way adjustable seat, adjustable side console, adjustable G-Motion™ handle position and adjustable steering column ensure operators of all sizes can find a place to do their best work.

## Two's not a crowd

When the days are long and a bit of company is needed it's nice to have a proper place for someone to sit. The padded training seat with seatbelt is large and comfortable without hindering the operator's vision or space. The seat also folds away to reveal a large storage area with optional cooling module for food and beverages.

## Keep your cool

The Australian summers can be long and hot, but that doesn't mean you should be. The fully integrated automatic climate controlled air conditioning system with carbon filter allows the operator to set and forget. Strategically placed air ducting ensures air movement is even around the cabin. There's even an overhead cooled storage compartment for a drink bottle.



# Cabin



# All within arm's reach.

Operator side console enables simple operation and functionality of all vital sprayer functions.

- ▶ Adjustable mounting of sprayer console is in line of sight, but low enough so it does not hinder the outside view.
- ▶ Multifunction engine and transmission monitor puts vital information at your fingertips.
- ▶ Push button transmission selector. Displays selected and actual gear.
- ▶ G-Motion™ handle. Adjustable position caters for all operators. Boom folding functions.
- ▶ Various machine functions like spray pump on/off, centre diff lock and boom recirculation just to name a few.
- ▶ Hinged padded arm rest which reveals a large storage area.

## Comfortable, adjustable and intuitive.

The new G-Motion™ handle literally puts the sprayer control into the palm of your hand.

Functions such as: Individual boom wing tilt, dual boom wing tilt, main boom lift/lower, fence line L/R, auto steer cancel/resume, cruise control set/resume and increase/decrease, master spray on/off mean all spraying operations can be done without moving your hand from the G-Motion™ handle.

- ▶ Cruise Set / Increase
- ▶ Cruise Resume / Decrease
- ▶ Cruise Cancel
- ▶ Boom Master On / Off
- ▶ Tilt Right Up, Tilt Left up  
Tilt Right Down, Tilt Left Down
- ▶ Boom Lift, Left Fence Nozzle  
Right Fence Nozzle, Boom Lower
- ▶ GPS Auto Steer
- ▶ Dual Tilt Up (Behind)
- ▶ Dual Tilt Down (Behind)



# Controllers



Any of these controllers can be fitted to the G8 Super Cruiser plus many more.



John Deere GreenStar™ 3  
- ISO Bus



TopCon X30  
- ISO Bus



Raven CR7™  
- ISO Bus



Trimble™ TMX® 2050  
- ISO Bus



Ag Leader® In Command  
- ISO Bus

# Control Freaks!

Introducing the latest in ISO BUS technology, the Raven RCM controller.

The ISO BUS standard is now considered the platform of choice for sprayer operators. It allows multiple brands of sub systems to all communicate through the one console. This allows operators to use the same preferred console across many pieces of farm machinery.

The latest iteration of this platform is the Raven Control Module (RCM). The RCM uses Raven's latest technology and brings many new features to help make precision farming simpler. Features such as:

Dual screen capability: with so many systems on the sprayer some consoles can struggle to display all the information easily. With the two screens

the operator can choose which information they would like to display on which console. For example, the mapping and guidance information could be displayed on the larger screen whilst rate information displayed on a smaller CR7 screen.

16 boom section control: Control up to 16 sections in single line 3TS or the new 3TS Pro (3 nozzle system). Smarter internal circuitry has eliminated the "smart box" nozzle switching hardware which increases system reliability.

Bluetooth connectivity allows operators to connect their phone or tablet to the sprayer for remote nozzle checking. This greatly speeds up the nozzle checking operation.

# Control Station





# Fluid distribution system.

---

When your sprayer is sitting idle being reloaded with water and chemical it's not making you money. That's why Goldacres offer filling solutions that minimise the reload time to have you back in the paddock sooner.

Options like fully integrated water and chemical transfer pumps, or fast fill 3" systems. Or maybe a separate batching system to complement your spraying program is of interest?

## **SuperFlow chemical induction hopper**

The SuperFlow chemical induction hopper is an integrated chemical transfer system that allows liquids, granular and powdered products to be measured and transferred into the main tank. The hopper has 60L capacity with both drum and internal rinsing capabilities. The high flow 2" venturi is mounted at the base of the hopper which draws the chemical into the water stream at that point, minimising the chance of blockages.

## **Water transfer pump**

When you need to transfer water into the sprayer quickly and conveniently the optional hydraulically driven transfer pump is the answer. The pump is plumbed directly to the EZ control

pod and can distribute flow to not only the main tank but also rinse water tank, main tank flush sprinklers, hopper flush, micromatic coupler and external wash down gun.

## **Operator safety and external controls**

Today's tough OH&S requirements are there to ensure everyone finishes the day like they started. Safe and well. At Goldacres we not only take care of our own employees, but we ensure operators of our products are also looked after. Features such as the clearly labelled and colour coded EZ control pod, well laid out connection points and valves at correct working heights, personal protective equipment (PPE) locker, hand washing and empty container rinsing equipment just to name a few. External switches with protective covers allow the operator to increase engine RPM, switch on the transfer pump and control the main sprayer pump, all from ground level.

## **Liquid chemical transfer systems**

When large quantities of neat chemical need to be transferred into the sprayer from either a 1000L intermediate bulk container (IBC), 110L envirodrum or a standard 20L drum then the chemical venturi probe or optional micromatic coupler can be used. The micromatic coupler arrangement is a complete closed loop connection system that eliminates the chance of the operator coming into contact with the chemical. The main sprayer pump is used to generate flow through a venturi, which creates a vacuum for the chemical to be drawn in. At no stage does the chemical come into contact with the pump and is therefore virtually a maintenance free system. If you require a separate system then a 12 volt chemical transfer pump and counter arrangement can be fitted. Both the probe and micromatic coupler can be used.

# Driveline

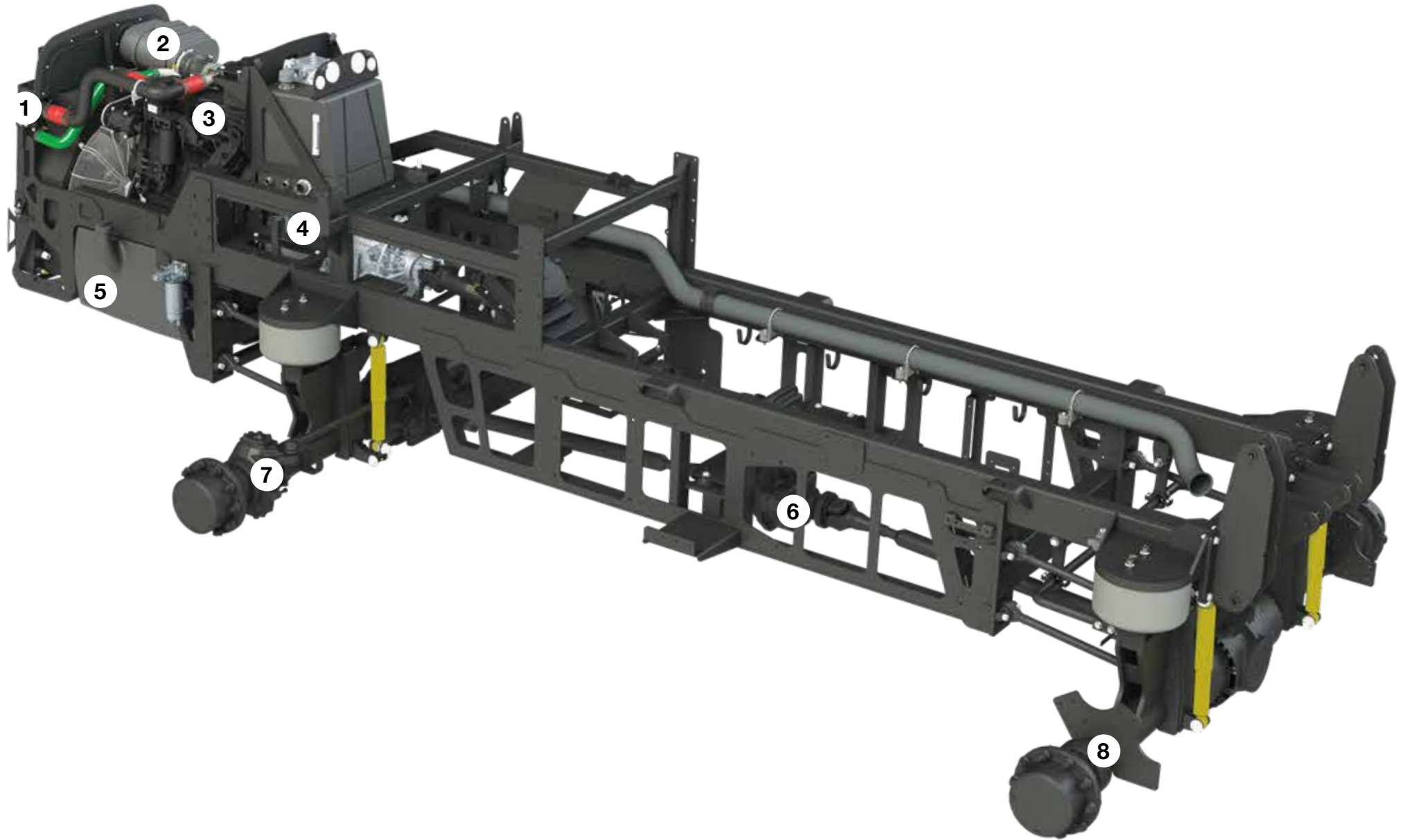

# Unparalleled driving dynamics.

Providing the foundation for the machine is the rigid chassis, suspension, and mechanical driveline.

The main chassis is a fully welded, torsionally rigid semi truss structure. This offers not only the best sprayer and boom ride, but also the optimum balance between strength and weight. The proven 5 link suspension featuring polyurethane bushed heavy duty torque rods, rear anti-sway bar and air springs on all four corners provides a stable smooth ride. All this combined with the full mechanical driveline results in performance on the ground.

## 1 Cooling System

Large vertically stacked cooling system for fuel, transmission, water jacket, charge air and air conditioning. Optimised cooling fan to reduce noise whilst still providing maximum air flow.

## 2 Over the Radiator Air Cleaner System

Has twin stage filtration provides cool clean air to the engine.

## 3 Engine

Cummins Tier 3 QSB 6.7L – 6 cylinder engine rated to 194kw (260hp) and 987N.m (728 lb-ft).

## 4 Transmission

Allison 3000 series 6 speed automatic transmission with electronic push button selector. Double overdrive reduces engine RPM whilst still maintaining 50km/hr transport speed. Lock up torque converter improves performance whilst drastically reducing heat build up and fuel usage.

## 5 Fuel Tank

300L polyethylene fuel tank with both left & right hand side filling points provides enough fuel for the longest spray days.

## 6 4WD (Full-time)

Lockable centre differential provides a 50/50 power split between front and rear axles. An internal ratio step down of 30% reduces drive shaft speed, resulting in longer universal joint life, reduced noise, vibration and harshness (NVH).

## 7 Front Axle

Front axle features extreme rated planet hub reduction design with internal wet multi disc brakes. Fully incorporated suspension mountings and mechanical link between front wheels ensures correct Ackerman angles and alignment.

## 8 Rear Axle

Rear axle features extreme rated planet hub reduction design with internal wet multi disc brakes, negative park brake and differential lock. Fully incorporated suspension mountings including the anti-sway bar and tow bar point round out the package.

Driveline





# Mechanical Advantage.

---

**Today's farmer must evaluate capital equipment purchases carefully to ensure that the return on investment is maximised.**

With all the models and options available today the choice has never been greater, or harder. Look past the sticker price of the initial purchase, dig a little deeper and substantial variations in sprayer design can make all the difference. This is where the Goldacres Super Cruiser mechanical drive line system sets it apart from its hydrostatic drive competitors.

These all equate to substantially lower operating costs. Reports back from owners state that the Goldacres Super Cruiser can use up to a third of the fuel than some hydrostatic drive sprayers in the same situation. So when the time comes to make that important purchase, dig a little deeper and turn the Goldacres mechanical advantage into your advantage.

There are numerous benefits with a mechanical drive sprayer, such as:

- ▶ Less maintenance costs
- ▶ Less noise
- ▶ Significant fuel reduction
- ▶ Less heat generated
- ▶ Lower engine rpm
- ▶ Lower horsepower required
- ▶ More torque at the wheels
- ▶ Longer component life.

# Weight distribution





# It's a fine balancing act.

---

**Perfect weight distribution provides superior sprayer performance and operator comfort.**

The cabin is mounted behind the front axle to give a naturally superior ride due to reduced vertical movement. In addition, the suspended cabin, air seat and five link airbag suspension system give the operator a smooth ride. The main tank is strategically located between the front and rear axles, in conjunction with the boom, cabin and

engine drive line positioning delivers a sprayer with an almost perfect 50/50 weight split. This reduces ground compaction by evenly distributing the weight across all four tyres. The result, perfect balance.

Booms 36-48m







# A sprayer is only as good as its boom.

36 to 48m TriTech V boom.

---

Today's sprayers are full of bells and whistles which makes spraying a whole lot easier, comfortable and efficient, but it's easy to forget what the end goal is. Precise chemical application.

Boom control can be the difference between a good spray result, and no result at all. Goldacres understand this and it is why all our sprayer designs are centred around the boom first and foremost.

## **Why do Goldacres booms ride so well?**

Goldacres pioneered the use of lightweight aluminium in the outer boom wings over two decades ago. The philosophy was, and still is today that mass on a boom is fine so long as it is as close to the centre as possible. Reduced mass on the boom extremities reduces boom forces in both yaw and roll. This combined with the unique

boom suspension results in a very stable boom ride, regardless of the terrain.

TriTech booms are contour following, meaning that the boom level will be referenced to the sprayer chassis and not purely on gravity such as a pendulum boom. This allows the sprayer to transverse the sides of hills and contours whilst keeping the boom level to the ground at all times. This results in placing the nozzle at the optimum height above the target.

# Booms 36-42m



# Features & benefits TriTech V boom.

TriTech V Series boom range is designed for operators who demand the utmost performance, reliability and control. Time and time again the TriTech boom has been named No.1 for boom stability\*, which at the end of the day, achieves a superior spray result.

## 1 Outer boom wings / breakaway

- ▶ Outer boom wings are aluminium trussed construction for exceptional strength, chemical resistance and lightweight.
- ▶ Boom breakaways feature a three dimensional break forward, back and up mechanism.

## 3 Boom fold

- ▶ Boom fold functions are operated via rocker switches / outer wing latching secures the boom for transport.

## 4 Boom Centre

- ▶ Boom centre section incorporates the proven TriTech suspension to dampen the forces of Yaw, Roll and Pitch.
- ▶ XRT radar boom height control system is fitted standard.

## 2 Inner boom wings

- ▶ Inner boom wings are manufactured using RHS trussing with nozzle bodies protected behind the boom structure.
- ▶ Hydraulic Bi-fold is built into the design.

## 5 Boom Plumbing

- ▶ ¾" boom plumbing mounted behind boom structure, infinite nozzle spacing.



\*Kondinin group's Farming Ahead magazine 2012 and 2014

Booms 48m



**48m**  
TriTech V boom

# 48m of controlled spraying accuracy.

48m TriTech V boom.

Productivity and flexibility when you need it, 48m, 36m or 20m spray widths at the push of a button.

The 48m TriTech V boom is constructed as a tri-folding design. This method of boom construction dramatically reduces the overall folded length of the sprayer compared to two fold booms making storage and transporting much easier. Clever packaging of the folded sections results in a relatively narrow transport width of just 4.3m without impeding on operator entrance to the cabin. The tri-folding construction also allows for multiple spray widths to be achieved. The boom can be operated in either 48m, 36m or 20m widths.

## 1 20m spray width

- ▶ Mid and outer section folded back.

## 2 36m spray width

- ▶ Outer section fold back.

## 3 48m spray width

- ▶ Fully open.



# Booms 48m



# Features & benefits of the 48m boom.



**33%**  
Increased productivity\*



A 48m wide boom compared to a 36m can potentially achieve a 33% increase in productivity (depending on application rate).

- ▶ 36m boom at 25km/hr = 90ha/hr.
- ▶ 48m boom at 25km/hr = 120ha/hr.

## 1 Centre Section

- ▶ Provides control for the boom. Featuring TriTech suspension, the centre section uses hydraulics to control boom yaw and dampeners for the roll. Pitch of the boom is controlled via hydraulic accumulators fitted to the paralift arms.

## 2 Inner Wings

- ▶ Steel RHS truss structure provides strength and flexibility to support the mid and outer wings.
- ▶ Accumulation is built into the fold cylinders to provide cushioning when accelerating or decelerating, reducing forces on the entire boom.

- ▶ A latching mechanism supports the mid & outer boom wings to the inner, while in the 20m working and transport position.

## 3 Mid & Outer Wings

- ▶ Full truss aluminium construction to provides strength and lightweight.
- ▶ Three dimensional breakaways and fitted to the end three meter boom section.

## 4 Plumbing

- ▶ 1" boom plumbing is fitted for both higher application rates but to also reduce pressure drop along the length of the boom.

## 5 Height Control

- ▶ XRT radar boom height control is fitted as standard – Ref pages 32-33.

\*36m boom to a 48m potentially 33% increase in productivity (depending on application rate)

# Booms





# Radar boom height sensing technology.

AutoBoom XRT radar sensor technology uses simultaneous ground and canopy detection to maintain optimal spray height for maximum product efficacy.

Pressure-based control allows for smooth movement and quicker reaction time while centre rack stability technology with variable dampers gives the system complete boom control.

## 1 Centre section

- ▶ The variable rate dampeners are used to stiffen the centre section roll action when wing tilts are operated. This allows much quicker reactions to occur without effecting the overall stability of the opposing boom wing.

## 2 Height sensors

- ▶ The height sensors use radar based distance technology. The radar sensors enable a larger height measurement range, can detect both ground and crop canopy and are less effected by spray drift, dust and mud.
- ▶ The system uses additional sensors to monitor the sprayer chassis rate of roll, the boom centre position relative to the chassis as well as boom wing tilt angle. These extra sensors allow the computer to predict how the boom will react well before the radar sensors even see the change in boom height. The end result is a more stable boom in uneven terrain.



# Boom Suspension

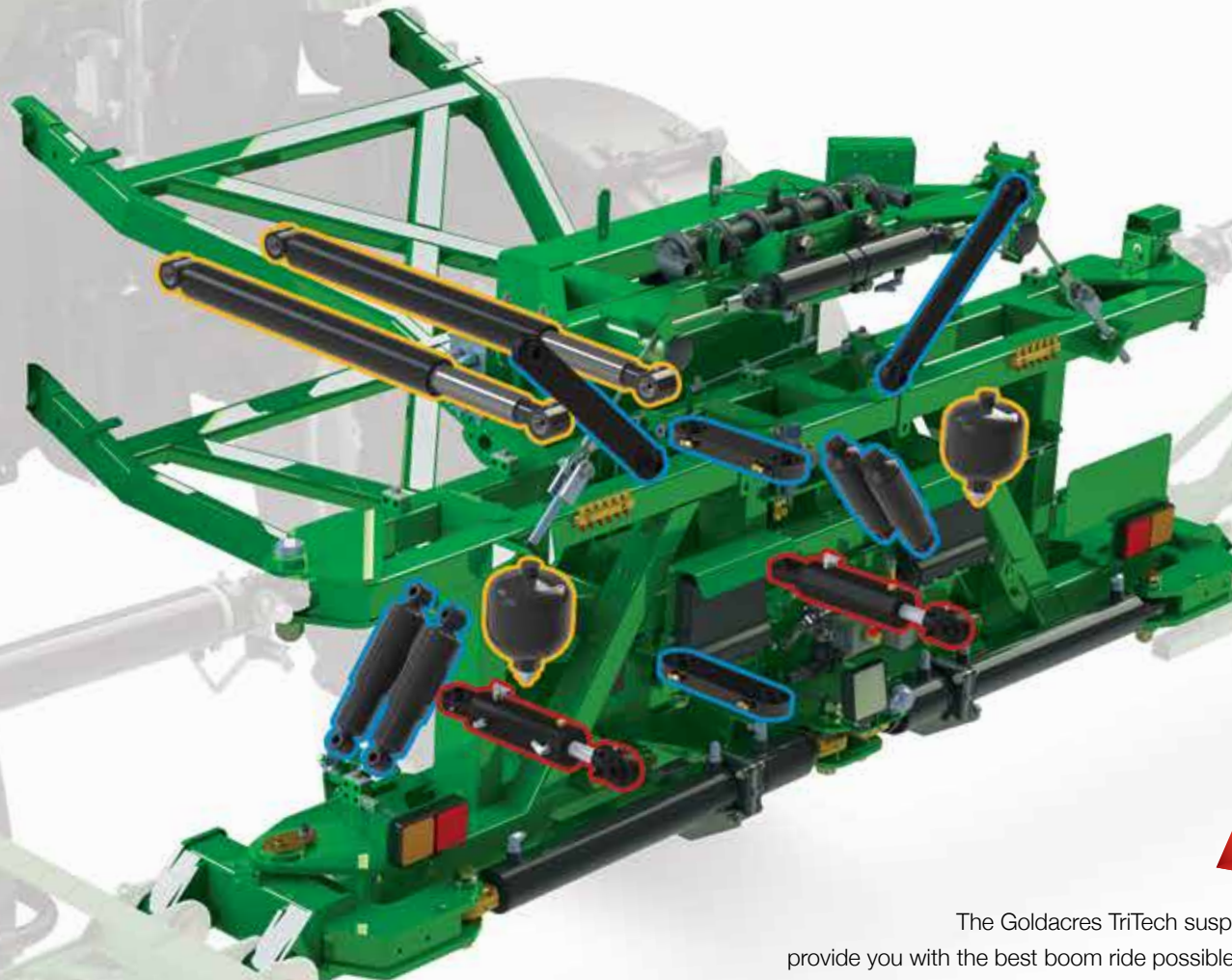

The Goldacres TriTech suspension system has been developed to provide you with the best boom ride possible and assist in an accurate application.

Working in conjunction with the chassis airbags the boom features three way suspension that works to reduce boom pitch, roll and yaw - the three enemies of accurate application. Hydraulic cylinders and accumulators work together to provide the best boom ride possible.

The TriTech suspension system has contributed to Goldacres consistently having the best boom ride in the spraying industry.

# Centre of attention. The underlying key to boom stability.

TriTech boom centre section – Why is boom ride and stability so important?

A boom which bounces, sways or yaws deposits chemical unevenly on the target. This can result in weed escapes and may even contribute to resistant weeds.



## 1 Pitch

- ▶ The boom parallelogram lift provides 1200mm of boom height adjustment as well as the vertical boom suspension (pitch).

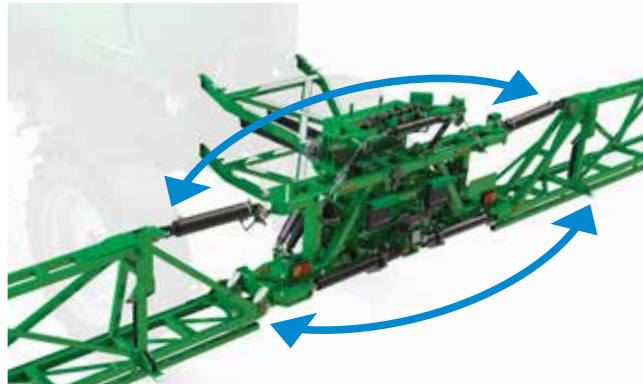

## 2 Roll

- ▶ The key to the superior boom ride is the strategically placed delta links. In all, there are four links. Each link features spherical ball ends which allow the centre to move in all directions. The roll centre point is the location at which the boom pivots around, both in roll & yaw. Roll dampeners reduce high-frequency oscillation of the boom roll.



## 3 Yaw

- ▶ Two opposing hydraulic cylinders are mechanically connected together either side of the pivoting boom centre section. As the centre yaws one cylinder is retracted, the other is extended. This results in oil movement which compresses in a nitrogen charged accumulator. The result is precise boom yaw control.

# Chemical Handling



# Batching, mixing & product loading.

Every agricultural operation is looking to improve its efficiency wherever possible. Correct batching and mixing of product to the label is the start of any spraying task. The ultimate in mixing and transferring chemicals is the 800L Goldacres BatchMate\*.

This standalone batching system allows chemicals to be pre-mixed easily, safely and quickly ready for transfer into the sprayer via the dirty 3" connection point on the sprayer. The BatchMate features its own high flow engine driven centrifugal pump so there is no need to leave the sprayer engine running whilst filling, substantially reducing engine hours over the duration of the annual spraying program. All the controls are well labelled and laid out to make chemical transfer safe and intuitive. For more details on the BatchMate refer to your Goldacres dealer.

- ▶ 800L product tank.
- ▶ Venturi chemical induction probe.
- ▶ Drum buster bag splitter.
- ▶ 23L handwash tank with soap dispenser.
- ▶ Drum / Jug rinse nozzle with stainless basket.
- ▶ 3" transfer outlet.
- ▶ Honda GX200 petrol engine and 3" high volume centrifugal poly pump.



\*Batchmate sold separately.

# Application Technology



16 boom sections for less overlap

# Optimising chemical application with RapidFire and RapidFlow.

RapidFire is instant boom nozzle on / off capability with 16 section control. Quick line priming and flushing of spray lines with RapidFlow boom recirculation.

## RapidFire

Goldacres pioneered RapidFire technology on Australian built sprayers in 2006. At the time the new technology vastly improved section switching times by replacing traditional motorised boom section valves with air controlled switching right at the nozzle.

RapidFire DM (Direct Master) further improves on this by moving the electric over air solenoid from a bank in the centre of the sprayer to the first nozzle of each section. This results in a significant reduction in air hose required and also evens up the switching time across all sections of the boom.

The boom is configured in 16 sections to improve spray resolution when using an auto section controller for odd shaped paddocks. Goldacres have determined that 16 sections provides the perfect balance between spray overlapping and complexity.

## RapidFlow (Boom Recirculation)

RapidFlow allows the sprayer boom lines to be fully primed without spraying a single drop. This reduces wastage at the start of a tank load or when switching chemicals. RapidFlow

can also be used to thoroughly flush out the boom lines without the need to physically spray on the ground.

# Application Technology





# Ultimate control and flexibility with 3TS and 3TS Pro.

Nozzle technology has advanced in leaps and bounds over the years and a strong emphasis on drift control has influenced many nozzle designs.

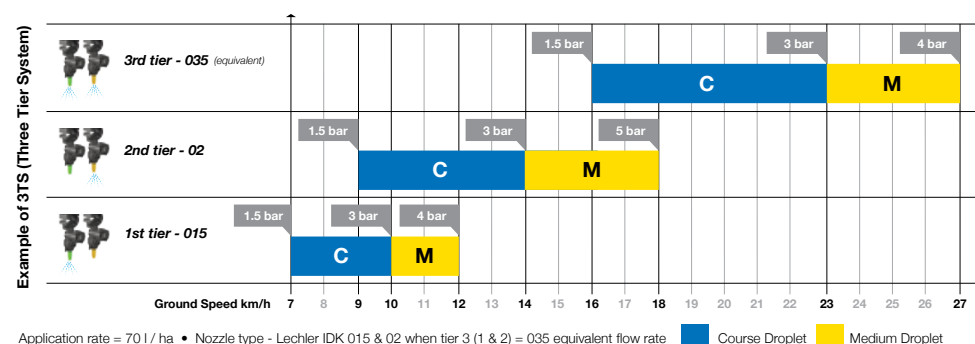

## 3TS

The spray nozzles operating pressure range and size determine the application rate and speed band at which the driver must adhere to. This band is usually quite narrow. Goldacres offer a 3 tier system (3TS) which effectively gives the driver a much wider operating band whilst still maintaining optimum droplet size.

Think of 3TS as a three step gearbox. Each

nozzle type has an operating pressure band for a given droplet size. As the first nozzle reaches the top of the pressure band it switches off and the next larger size nozzle switches on. When that nozzle reaches the top of that pressure band the first nozzle will switch on again, effectively giving three operating bands.

The table below shows the pressure variations of two common nozzles, 015 & 02 operating at 70 l/ha through their respective pressure ranges from 7 km/h through to 27 km/h.

## 3TS Pro - the ultimate control and flexibility without leaving the cab.

The 3TS Pro is essentially our 3TS system with an added nozzle to give a wider range of spray rates without manually changing jets.

*If you are constantly changing rates but want to keep your speed consistent, the 3TS Pro is for you.*

For example you may want to apply 70 l/ha with your combination of 015 & 02 nozzles to give the overall capacity of an 035 nozzle (as

per 3TS chart shown), then increase your rate in certain parts of the crop, other paddocks or even in the application of fertilisers.

In most cases you would need to slow down to increase the rate as you would previously exceed the nozzle pressure range. With the additional nozzle the 3TS Pro will automatically select the best nozzle combinations for your speed and rate while maintaining the working pressure range of the nozzles.

# Application Technology



# Hawkeye<sup>®</sup> - Nozzle control system.

Pulse Width Modulated (PWM) technology is now available as an option for your Goldacres sprayer.

PWM technology uses a small electrically operated solenoid mounted to the nozzle body to control the flow rate delivered to each nozzle. The system rapidly pulses the nozzle on and off at rates of 10hz (10 times per second) whilst also adjusting the amount of time the nozzle is opened and closed (this is called the duty cycle). The spray line is set to maintain a constant liquid pressure, whilst the computer adjusts the duty cycle to vary the application rate. The system allows the selected nozzle to operate at a target droplet size independent of the forward speed (within the system and nozzle capacity)

Using the PWM technology also provides a method of providing turn compensation. When making a turn the inner wing tip speed slows and the outer wing tip speeds up, which in turn over and under applies chemical to the target. As each nozzle is controlled independently it is possible to adjust

the duty cycle to either decrease or increase the application rate across the entire width of the boom.

Features:

- ▶ Nozzle by nozzle turn compensation.
- ▶ 16 virtual sections or the option to have individual nozzle sections.
- ▶ Fully integrated into the G-Hub system as well as ISO BUS compatible.
- ▶ Available in either 250mm or 500mm spacing.

## 1 Without Hawkeye<sup>®</sup>

- ▶ Over apply on the inner and under apply on the outer wing when turning.

## 2 With Hawkeye<sup>®</sup>

- ▶ Consistent coverage when turning. Note: within nozzle parameters.

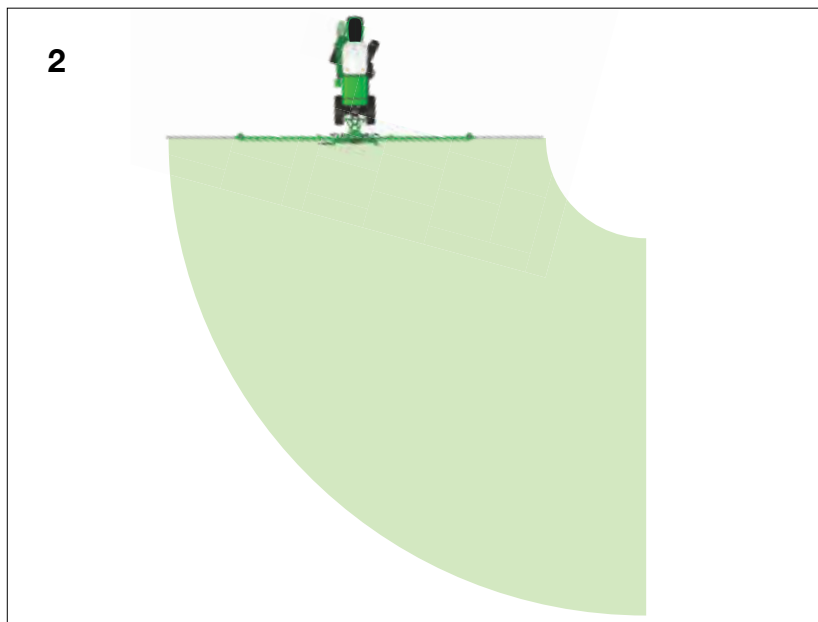
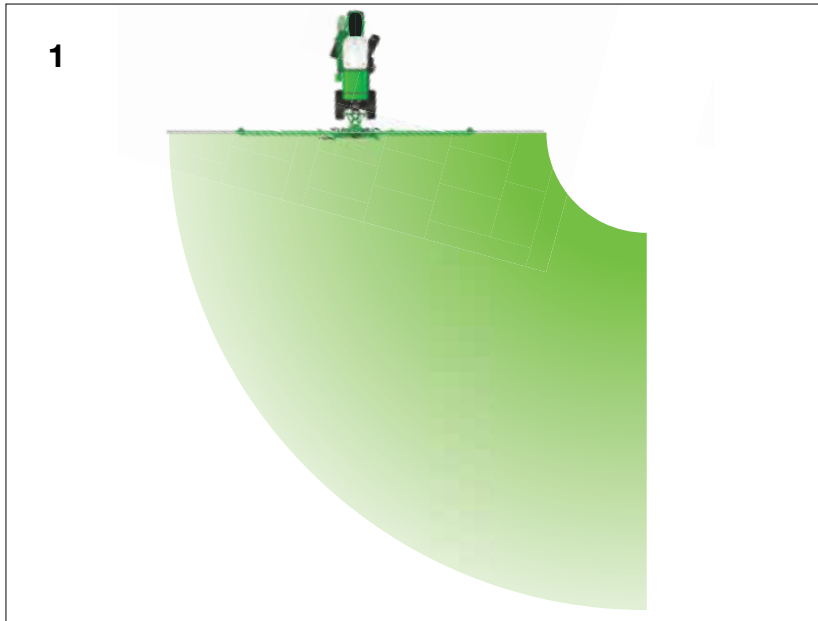

# Transport



# Ease of transport.

Whether you're spraying in the field or driving down the road, uninterrupted vision around the sprayer is essential for the safety of you and others.

Features like the flat folding boom wings so the operator's line of sight is uninterrupted. Electrically adjustable side mirrors provide a clear view of the road behind. 360° rotation windscreen wiper blade for maximum cleaning area of the front window. Hydraulically adjustable LHS boom rest provides the operator with easy access to the cabin in the wide position yet brings the overall transport width down for road transport\*, eliminating the need for an escort vehicle. Twin circuit, 4 wheel internal multi-disc brakes fitted as standard. LED

daytime running lamps, turn indicators, high / low beam projector style halogen head lights and twin rotating warning beacons round out the package. The Super Cruiser really is one for the road.

Dimensions	A (m)	B (m)	C (m)	D (m)	E* (m)
36m boom	4.3	3.6	9.85	4.45	.94
42m boom	4.3	3.6	10.4	4.45	.94
48m boom	4.3	4.3	9.35	4.45	.94



LED daytime lights



Boom Rest



In Cab View

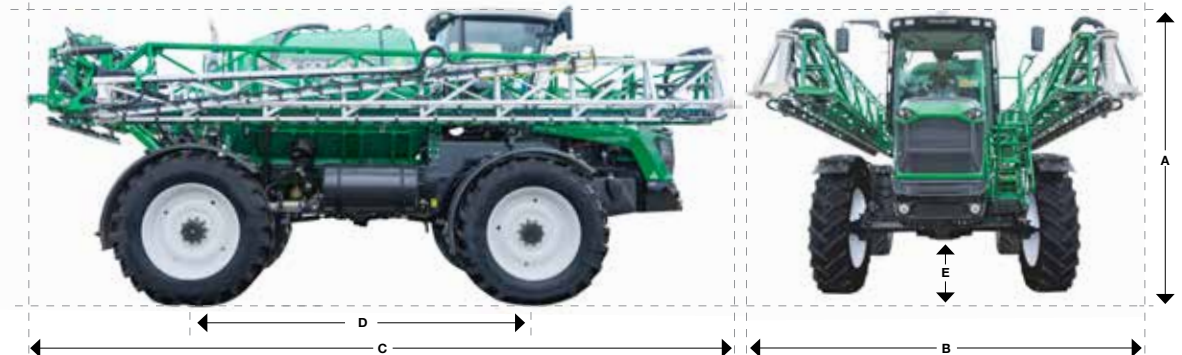

\*3.5m when 480/80R46 tyres fitted at standard wheel track 2970mm. ^Not on 48m boom.

# Specifications

## Engine

Cummins QSB 6.7L, 6 cylinder, Tier 3 emission. 194kw (260hp), 987N.m (728lb-ft)	Std
Vertically stacked combi cooler package. Fuel, transmission, water jacket, charge air & air conditioning	Std
Hydraulic driven cooling fan	Std
440L Fuel tank	Std

## Transmission

Allison 3000 series automatic. Push button selector, lock up torque converter, 6 forward & 1 reverse	Std
--	-----

## Drive system

Full-time 4WD	Std
Centre diff lock	Std
Rear diff lock	Std
Steering	
2 wheel front steering system	Std
Steering radius (machine centre point)	11m

## Hydraulics

100L plastic reservoir with level & temperature gauge (visible from driver's seat)	Std
63cc variable displacement hydraulic piston pump	Std
22cc gear pump (Fan and brake system)	Std
32cc gear pump for spray pump system	Std
Tank mounted return filter	Std
Oil Cooler	Std

## Electrical

12V – 160amp electrical capacity	Std
Dual batteries with master isolator	Std
Fully sealed connectors with color coded wires used throughout the wiring harness	Std
4 x LED front mounted & 2 x LED rear mounted roof driving lights	Std
3 x LED service lights	Std
LED light bar for lower bonnet (18x10W CREE)	Opt
LED light bar for upper cabin (12x10W CREE)	Opt

## Braking

Full hydraulic twin circuit system with accumulator backup	Std
4 x wet brakes inside axle housing	Std
Electric over hydraulic operated park brake on rear axle	Std

## Chassis

Fully welded, wide, semi truss, rigid mild steel	Std
200 x 100 x 9mm main rails	Std

## Suspension

5 link torque rods with rear sway bar. 4 x rolling lobe air springs with ride height levelling. Shock absorbers on all corners, front feature double knuckle for extreme axle articulation	Std
--	-----

## Paint

Grit blasted steel work followed by high build primer. All unwelded sections seam sealed	Std
Wet top coat paint system with high temperature baked finish	Std

## Wheels and track width

520 R46/85 tyres	Std
3m axle track	Std
4 x full length axle mounted polyethylene mudguards	Std

## Cabin

Business class styled cabin with suspension	Std
Dual tilt and telescopic steering column	Std
Air suspension seat with seat belt. Fully adjustable	Std
Training seat with seat belt	Std
Accessory mounting rail on RHS	Std
Window tint for all 4 sides	Opt
Carbon filtration with positive cab pressurisation	Std
Bluetooth equipped radio and UHF with high gain antennas	Std
LHS access platform with auto folding ladder. Hydraulically adjustable width LHS boom rest for ease of access and convenient road transport	Std

## Boom

TriTech V Series flat folding boom. Mild steel inner wings with aluminium outer wings and breakaway.	Std
Available in the following widths. 36, 42 & 48m. All booms plumbed in 16 sections	Std
RapidFire single line in 500mm spacing	Std
RapidFlow boom recirculation	Std
3 tier system (3TS)	Opt
3 tier system Pro (3TS PRO)	Opt
Raven Hawkeye (PWM system with turn compensation)	Opt
Trijet nozzle bodies	Opt
Cross fire 3TS (3TS capability with nozzles staggered every 250mm)	Opt
Custom nozzle spacing and configurations on request	Opt
Hydraulic wing tilt	Std
Hydraulic bi-fold (36 & 42m) tri-fold (48m)	Std
Hydraulic yaw system	Std
Automatic boom height control system	Std
Remote fence line jets	Std
Spray control system	
Raven RCM	Std
Raven CR7 display	Opt

## Solution tanks

UV stable polyethylene heavy walled tank. Supported in a steel cradle	Std
Main tank - 8000L	Std
Rinse tank – 500L side mount	Std
Dry sight tube mounted on LHS	Std

## Spray Pump

High flow centrifugal	Std
260 l/min, oil backed 6 diaphragm positive displacement. RPM readout	Opt
Suction filter plus twin pressure filters	Std
Chemical handling and transfer	
Chemical suction probe	Std
60L induction hopper	Std
Micromatic rinse socket and coupler	Opt
Pneumatic chemical transfer pump (40 l/min)	Std
3" integrated water transfer pump	Std
3" separate front fill	Opt
3" separate side fill	Std
Service / Maintenance	
Remote grease nipple bank	Std
Auto grease system	Opt

## Weight

Weights are approx. and depend on options fitted	
Tare weight* (kg)	12,075
Gross weight* (kg)	20,275

*\*Weights will vary depending on options fitted.*

**Goldacres Trading Pty Ltd**

1-3 Morang Crescent, Mitchell Park 3355

P: 03 5342 6399 | F: 03 5342 6308

goldacres.com.au

The policy of Goldacres is one of continuous development and improvement. Goldacres reserve the right to alter any specifications, designs and prices of the range shown without notice and without incurring any obligation regarding such changes. The pictures and information shown or referred to in this publication are a general guide only. Should you purchase the items from this publication the publication does not form part of the contractual arrangements with Goldacres. The purchase of any item of equipment is subject to the Goldacres Terms and Conditions of sale. 11/22 - GA8700542-R3

