



UNIA

ARES
DISC HARROW



uniamachines.com



UNIA Sp. z o.o. is a Polish manufacturer offering the largest complex range of agricultural products in Europe.

We own 4 modern factories, equipped with world-class production equipment. Our history and knowledge dates back to almost 140 years. First cultivator and reversible plough in the world were produced in our factory.

Our products, through specialized distributors, reach farmers in more than 60 countries of the world, on every continent.

Thanks to this knowledge, we offer our customers not only modern machines, but also the best agronomic solutions used in the world's most demanding markets.

We offer a complex range of agricultural equipment: ploughs and cultivators, seeding equipment and combination seed drills, spreaders, balers and bale wrappers, sprayers, potato harvesters as well as grain storage technology.

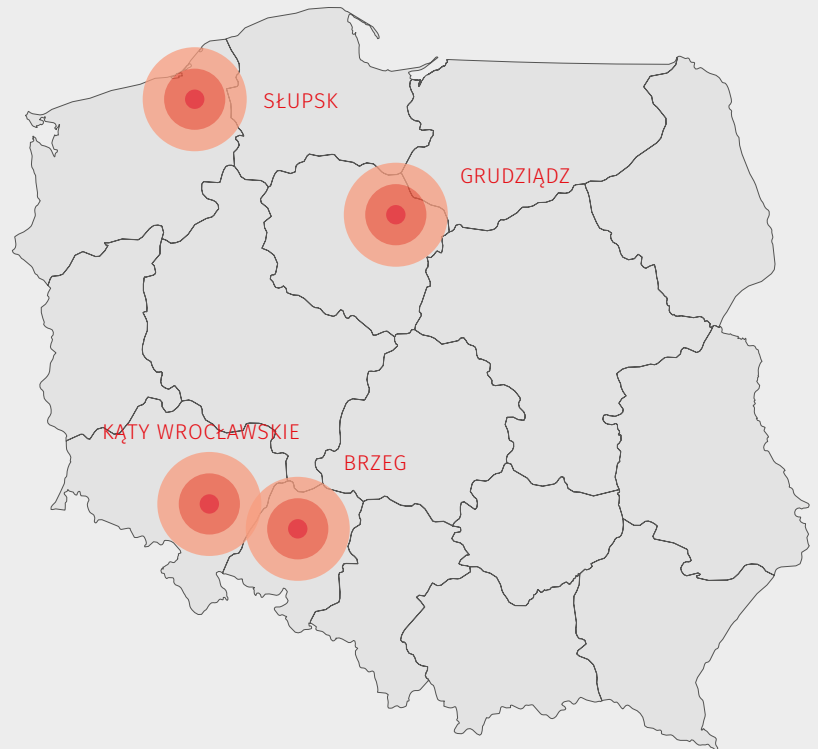

4

FACTORIES

11,5 ha

PRODUCTION
AREA

1200

EMPLOYEES

700

ITEMS
IN OFFER

60

MARKETS

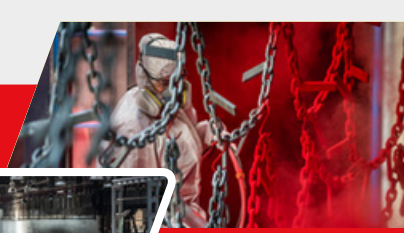
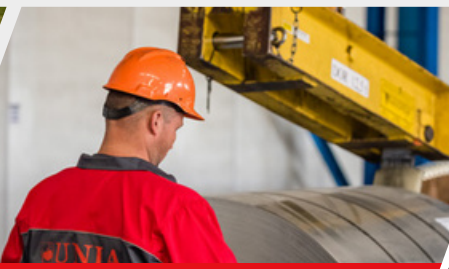

OVER 70 YEARS OF EXPERIENCE

IN THE DISC HARROWS

MANUFACTURING

The design of the first Polish disc harrow adapted to aggregation with a tractor was developed by the designers of Fabryka Narzędzi Rolniczych in Grudziądz in 1949. The model was marked as ŁBD-4.5 and had a working width of 4.5 m.

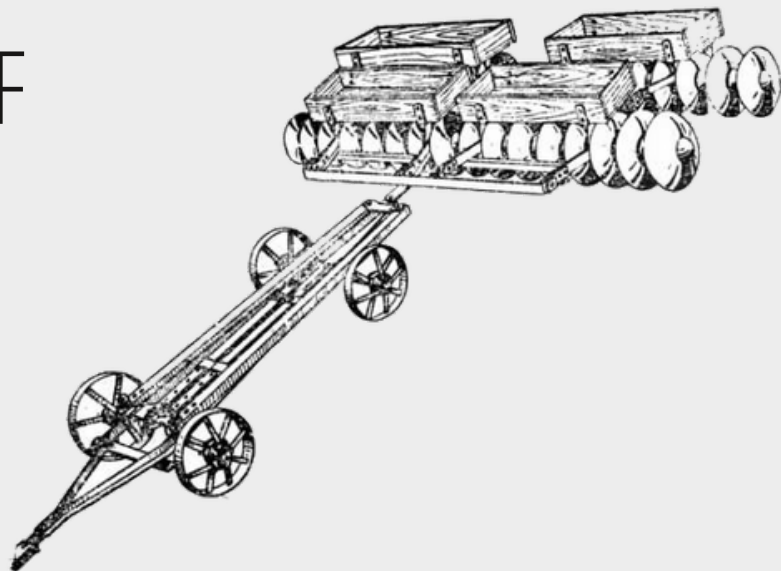



Innovative ARES

The year 2002 was the time when the ARES parallel disc harrows were introduced to production. UNIA was the first manufacturer in this part of Europe that started the production of a multi-purpose aggregate. The machine has introduced a new standard for stubble cultivation. It gained additional recognition thanks to the innovative concept of connection with a seeder, farmers were given the opportunity to create cultivating and sowing units for the first time.



PERFECTLY DESIGNED CONSTRUCTION

The ARES series consists of six models of compact disc harrows adapted to work on any farm.

The smallest one has 2.5 meters and the largest 12 meters of working width. Proven design and the possibility of configuration of working elements meet the farmers' requirements.





PERFECTLY DESIGNED WORKING ELEMENTS

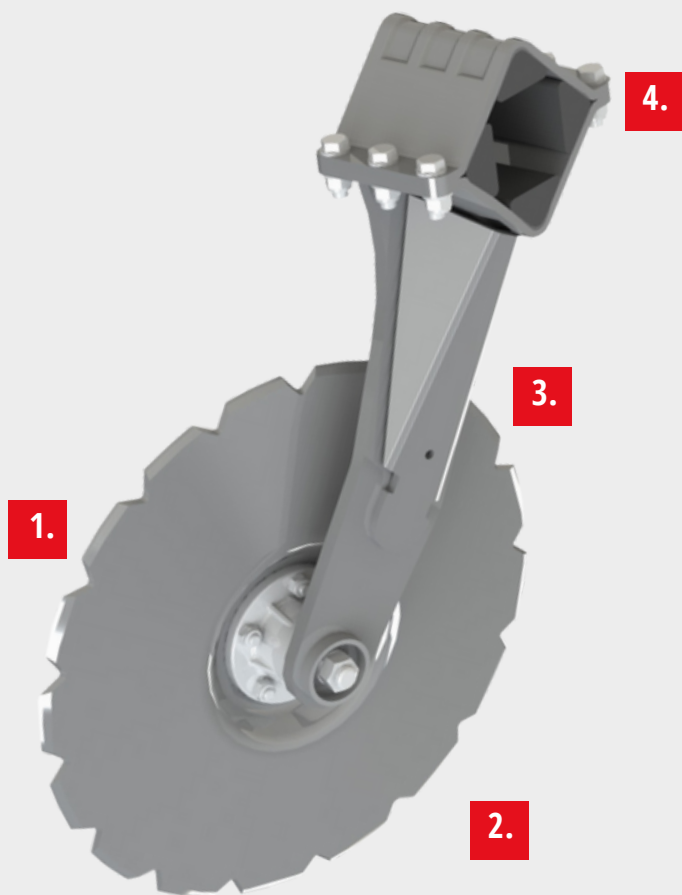

1. UNION DISC CUTTERS

Made of high-quality Swedish SSAB boron steel. The unique manufacturing process guarantees high durability, each plate is individually hardened. The cutters are evenly hardened and have exactly the same shape. All this translates into high durability in field conditions.

2. MAINTENANCE-FREE HUBS

They combine high strength, necessary for working in the field, and a compact design that does not obstruct the soil flow. They are attached to the plough standard with one screw. Lock openings ensure a permanent connection and facilitate service work. The hub nut is protected by a ring.

3. DISC FIXING SYSTEM



One plough standard holds one disc, which facilitates penetration of the cutters in the soil, maintaining the working depth and following the terrain. The profile of the plough standard corresponds to the shape of the disc and is made of HARDOX steel.

4. RUBBER SHOCK ABSORBERS

The triangular shape maintains a larger contact area with the beam and the disc mounting assembly. The cutters retain the same depth and the vibrating working elements do not transmit vibrations to the machine. The used mixture is of high quality and retains its parameters regardless of the temperature at which the work is performed.

DISC CUTTERS

Depending on the selected model of the ARES disc harrow, disc cutters are available in three different diameters: 510, 560 and 660 millimetres.

CLASSIC discs with small cut-outs around the perimeter are perfect for shallow stubble cultivation and for preparing the field for sowing. Small notches allow for intensive cultivation with shallow working depth..

AGRESSIVE discs are adapted to work with more harvest residues, on heavier soils. The elliptical shape and deep notches with sharpened edges allow to cut and mix large amounts of stubble residues and catch crops.

CLASSIC



AGRESSIVE



TX PROTECTION

Heavy disc harrows such as ARES ROLLER UP, P and HP can be equipped with spring protection for each of the discs.

This allows to work on heavily stony fields. The discs used in the TX system have a diameter of 660 mm, which allows them to work in conditions with a large amount of stubble residues.

The TX protection is available on the ARES ROLLER UP, ARES P and ARES HP disc harrows.

- 1. AGGRESSIVE APPROACH ANGLE**
- 2. THE SHAPE OF A PLOUGH STANDARD IN THE SHAPE OF A DISC CUTTER**
- 3. PLOUGH STANDARDS FITTED ON HARDENED SLIDE BUSHES**
- 4. PRE-CHARGED SPRING WITH LIMITER**

ADVANTAGES OF THE TX SYSTEM

- The working depth is maintained even on harder ground.
- The disc release force is 450 kg
- The discs are always guided with great accuracy.
- Optimum pressure on the individual discs, precise adherence to the working position and constant triggering force.
- Maintenance-free replaceable bearings

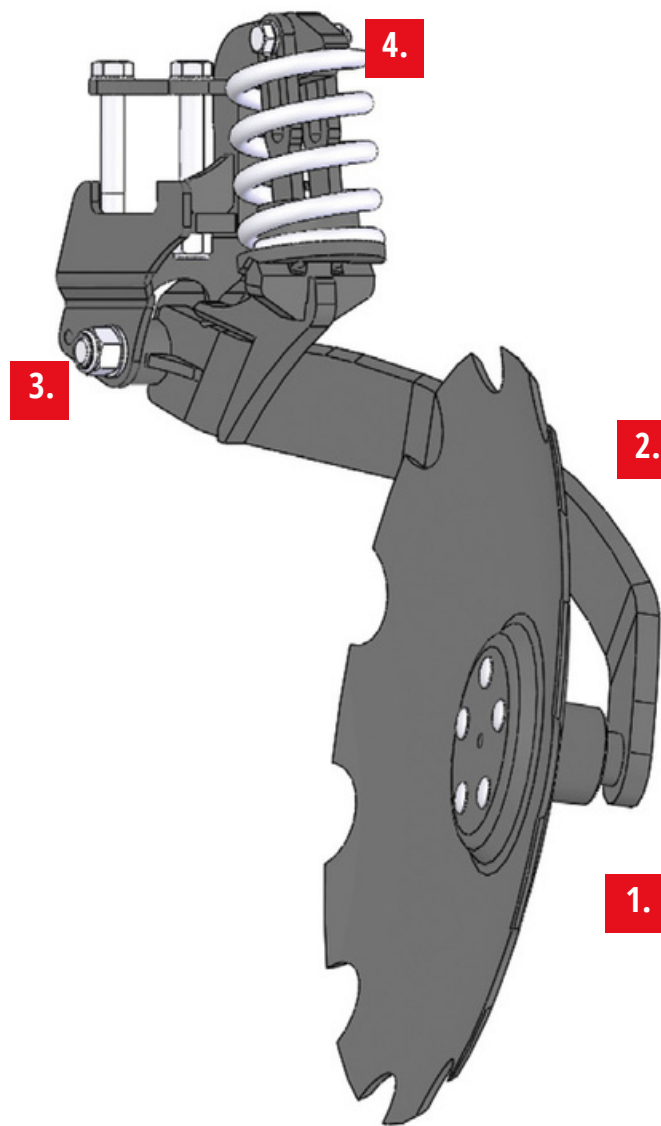





EFFECTIVE LAYOUT OF WORKING ELEMENTS

Unique approach angle of disc cutters.

The unique approach angle of the discs ensures full undercutting during stubble cultivation and intensive mixing of harvest residues with the soil.

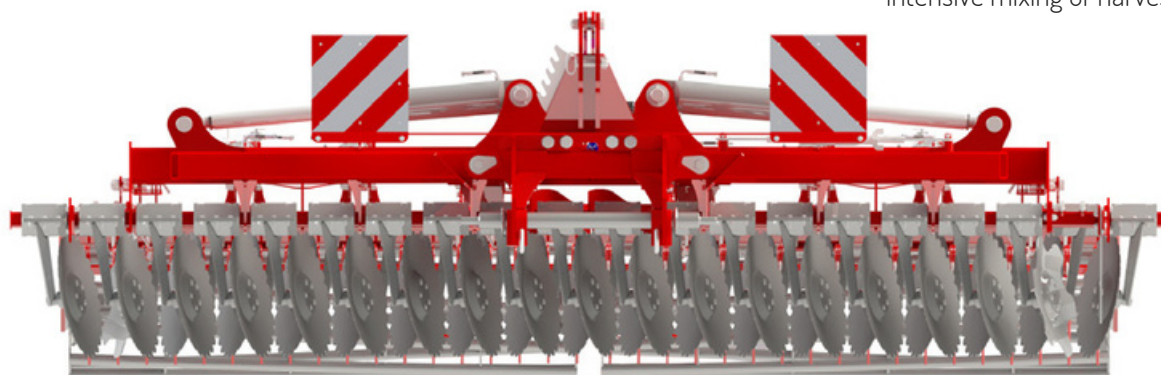

The arched shape of the frame allows for high ground clearance, which directly translates into the flow of cultivated soil and crop residues.

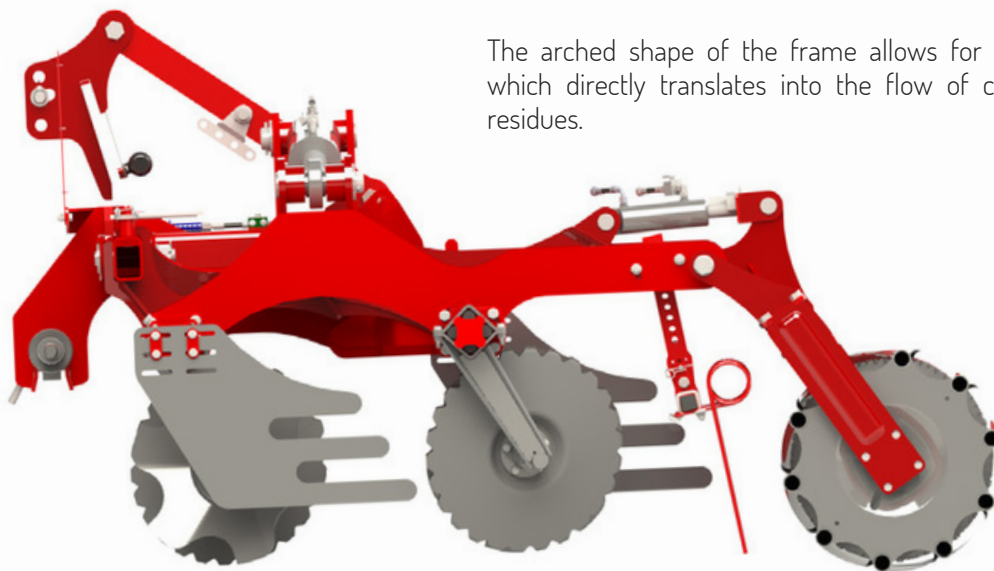



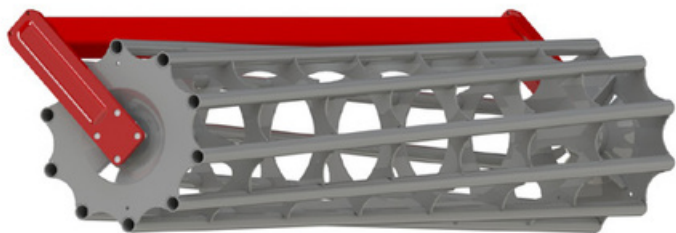

TUBE ROLLER

- It compacts light and medium soils best, while its low weight does not guarantee adequate compaction of heavy soils.
- It consolidates the top layer to a small depth.
- Its biggest advantage is the large contact surface with the soil, thanks to which the machine does not sink excessively and maintains the desired depth on light soils.

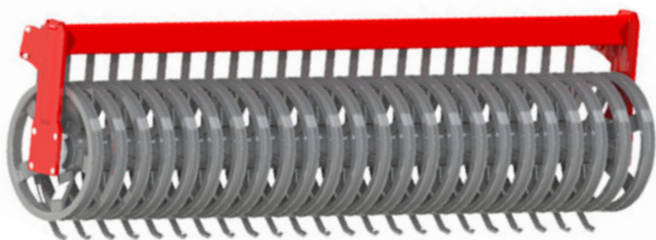

U- PROFILE ROLLER

- The U-profile rings fill with soil when working on clay soil, which prevents the formation of a crust on the field surface.
- On sandy ground, the large support surface of the U-profile allows to maintain the set working depth of the machine.
- The roller consolidates the soil in strips to an average depth.
- It is equipped with cleaning strips as standard.

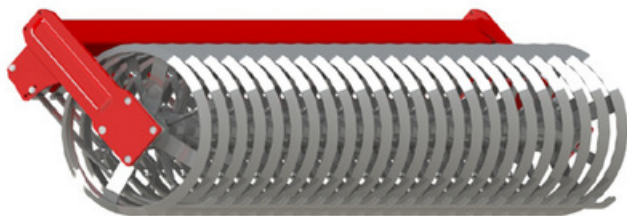

V-RING ROLLER (SPIRAL)

- The v-ring roller works best on heavy and compact soils.
- The structure made of V-shaped rings is great for crumbling of the clods of soil.
- The roller acts in stripes on the deeper layers of soil.
- Standard equipped with anti-clogging strips.

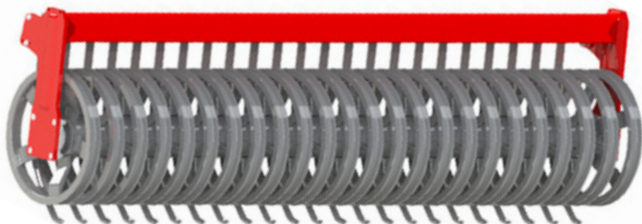

T- PROFILE ROLLER

- It has good crushing properties and maintains the lumpy structure of the soil.
- It makes the decomposition of crop residues easier.
- It compacts the soil deeply.
- Standard equipped with anti-clogging strips.

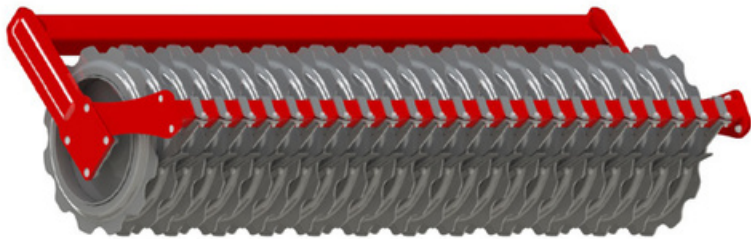

TIN ROLLER

- This is a heavy roller that provides strip consolidation.
- It improves the conditions of water and gas exchange in the soil.
- It crumbles and accelerates the decomposition of organic matter.
- Standard equipped with adjustable scrapers that can be turned inside out

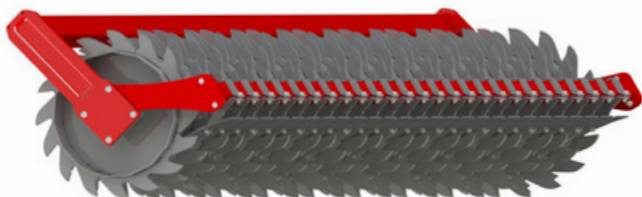

PACKER ROLLER

- The large support surface allows for work on lighter soils. It has good crushing properties.
- It creates an excellent seedbed.
- Equipped with adjustable scrapers.

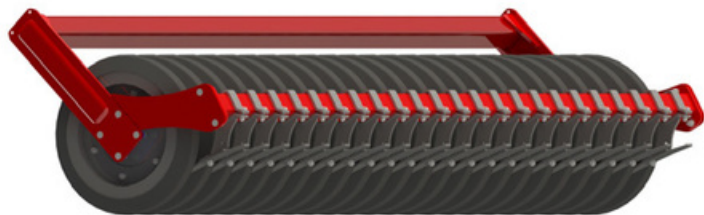

RUBBER ROLLER

- Consolidates the soil in strips, causing good soil soaking where the rubber rings work.
- It works perfectly in combination with a seeder, the seeds that hit the pit germinate quickly.
- Suitable for all types of soil.
- It is equipped with a set of scrapers as standard.



SYSTEM DRIVE

- The roller compacts the soil in strips corresponding to the width of the tires.
- Due to the use of tires with agricultural tread, there is no problem of clogging, so it can be successfully used on all types of soil.
- The wheels are mounted in pairs, which greatly facilitates any repairs.

FRONT MOUNTED ATTACHMENTS

Additional options for semi-trailed harrows

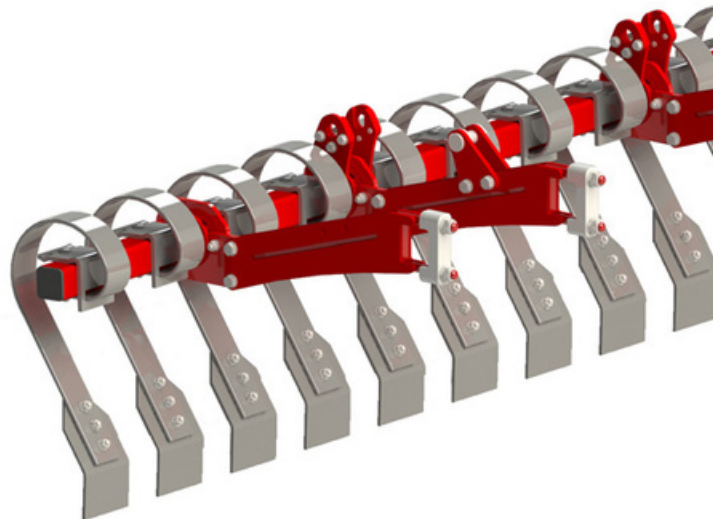

SUPPORT WHEELS

They are optional accessories for all semi-trailed ARES harrows. The wheels maintain the working depth, provide better ground following and stabilize the machine during operation.

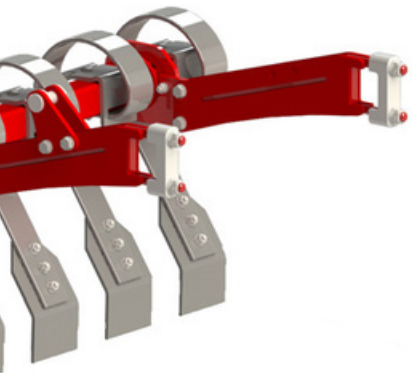

HYDRAULICALLY CONTROLLED LEVELING BAR

It works great in pre-sowing cultivation. The 150 mm wide plates mounted on springs crush larger clods of soil. The working depth is adjusted from the tractor cabin with the use of hydraulic cylinders.

The dragline can be fitted to the ARES L (semi-mounted and DRIVE versions),

ARES

XL and ARES XM models.



ARES XL
ARES XL
A



ARES XL
ARES XL
A



ARES
XM
ARES HP

FP SEED DRILL

UNIA disc harrows (except ARES ROLLER UP) can be equipped with a FP precision seeder for catch crops, during cultivation, plants with small and coarse seeds can be sown. UNIA FP allows to reduce the number of passes on the field.

FP seed drills work in the range of 5 - 350 kilograms per hectare.



▲
FP 250

FP 550





ARES XL

Modularity and the number of options at an additional cost allows to adjust the ARES XL to work on any farm. The model range starts at 3 m and ends with a 12 m wide machine.

After purchase, it is still possible to retrofit the machine with 480/45-17 wheels and front support wheels.

Air or hydraulic brakes can be combined with a variety of

tractors. The DRIVE system is also available on hydraulically

folded

machines. Wheels with a diameter of 670 mm mounted in two rows ensure stability during work.





Single or double rollers

RAEX 500 sheet, 16 mm thick

Extendable side
deflectors

Cutter of a smaller diameter
with deep notches



ARES XL

The frame is based
on a 160x160 mm profile



CLASSIC or AGRESSIVE discs

Suspension axle compatible
with UNIA machines

TECHNICAL DATA



110 - 260
power demand



3 / 3,5 / 4 / 4,5 / 6
/ 7,5 / 12 m
working width

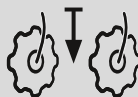

MAX 15 cm
max. working depth

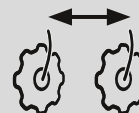

80 cm
spacing between rows
of discs

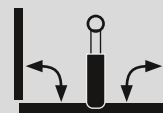

folding
hydraulic
(4 / 4,5 / 6 / 7,5 m)

ARES XL	3	3,5	4	H 4
Weight with pipe roller [kg]	1530	1875	2085	2470
Power demand [HP]	110÷130	120÷140	120÷150	130÷160
No. of discs [pc.]	24	28	32	32
Spacing between rows of discs [cm]	80	80	80	80

ARES XL	H 4,5	H 6,0	H 7,5	H 12
Weight with pipe roller [kg]	3075	3630	4485	13900
Power demand [HP]	150÷180	170÷210	190÷260	380÷480
No. of discs [pc.]	36	48	60	96
Spacing between rows of discs [cm]	80	80	80	80

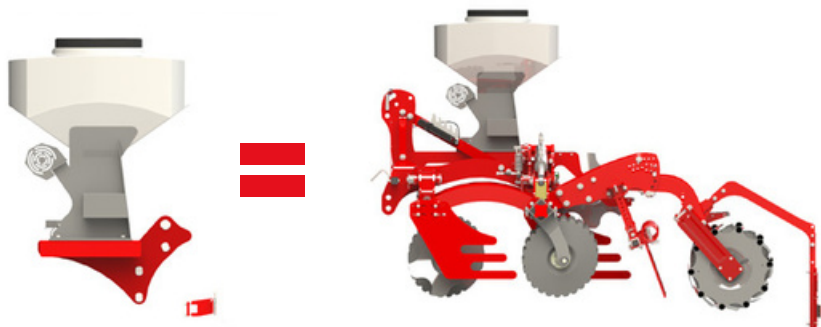

CREATE YOUR OWN DISC HARROW

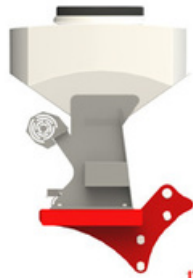

 **UNIA**



ARES XL SEMI-TRAILED

MASZYNA

Warianty homologowanej



480/45-17 wheels

Chassis can be disassembled

Hydraulic working depth adjustment

Braking system:
pneumatic, dual-line or
hydraulic

Semi-trailing axle with
variable category III/2 or
III

Extendable side deflectors

 **UNIA**



ARES XL SYSTEM DRIVE

MASZYNA



Tire Roller OffSet

Lifting cylinder of the machine with a pawl system

Front hydraulic dragline with a pawl system

Cable holder

High-pressure 670 mm diameter wheels with scrapers

Semi-trailing axle with variable category III/2 or III



ARES XL H 12

The ARES XL H 12 is a further development of the proven XL disc harrow design. The machine consists of two six-meter sections mounted on a solid chassis with 4 transport wheels. After folding, the machine does not exceed the permissible transport width - 3 m.



ARES XL H12

Lashings to stabilize the machine during operation

Three-point linkage systems

Chassis with 550/45-22.5 wheels with air brake

The chassis frame is based on a 120 x 220 mm profile

ARES XL A

ARES XL A is a soil applicator based on a proven disc harrow.

Thanks to the possibility of working without a roller, it can be aggregated with slurry tankers, the coupler of which does not have a high lifting capacity.

The ARES XL A applicator has a unique method of slurry application, which allows to minimize nitrogen losses and eliminate the unpleasant smell in the vicinity of the fields.

The dispensers mounted on the front row of discs convey the slurry directly into the furrow formed by the disc. The second row of discs covers the poured slurry with a layer of soil, which minimizes nitrogen losses.

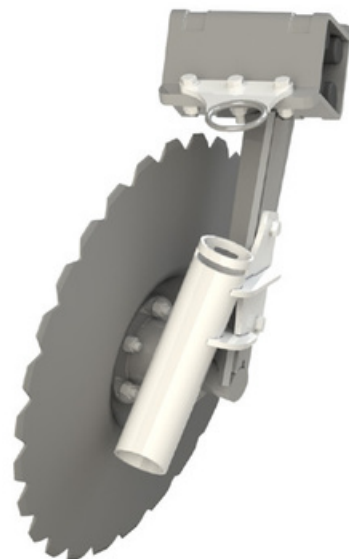

VOGELSANG DISTRIBUTORS

The ARES XL A applicator is equipped with a VOGELSANG dispenser attachment as standard, which are optional accessories. The universal mounting also allows the installation of other distributors.

DosiMatLVX

Maximum precision combined with carrying out several operations at the same time. The slurry flows down from the top then is evenly distributed by the rotor. Knives cut and crush solids.

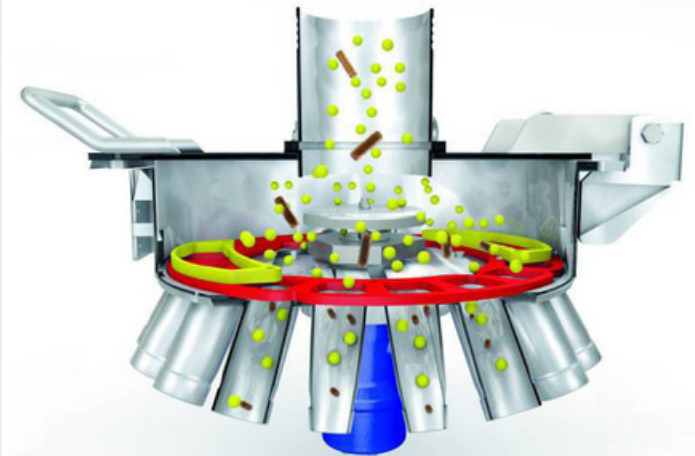

ExaCutECL

Simultaneous dosing, cutting combined with feeding the slurry to the sides of the machine. The distributor is equipped with a settler of solid particles, which protects the discs against damage. The knives are self-sharpening type.

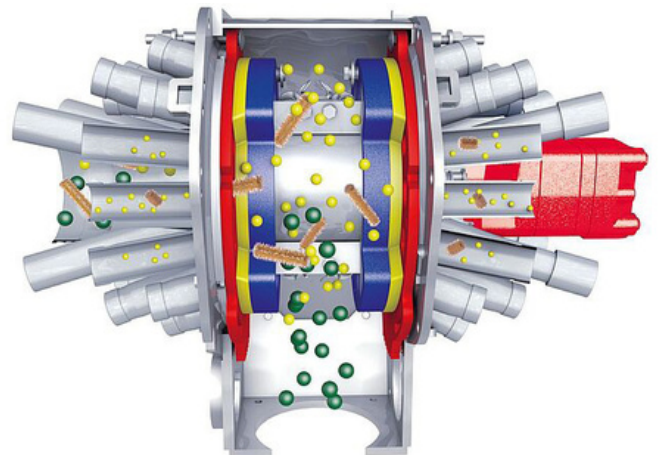



UNIA



UNIA Sp. z o.o.

ul. Szosa Toruńska 32/38, 86-300 GRUDZIĄDZ
uprawa@uniamachines.com

uniamachines.com